

# CLM2301x / 2305x Series Model & Parts No. Explanations

## CLM2301x Series Prtodution (See Page I3~I18)

**23010**

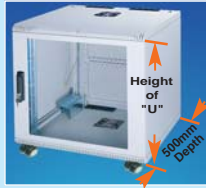

**23010-512**

Model No. of Wallmount	running Part No.	Depth in 500mm	Height in "U"	Color for ordering
------------------------	------------------	----------------	---------------	--------------------

**23012**



**23012-512**

Model No. of Wallmount	running Part No.	Depth in 500mm	Height in "U"	Color for ordering
------------------------	------------------	----------------	---------------	--------------------

(1) U-shaped mounting angle



**612011-2306**

Finished Part No.	running Part No.	Model No. of	Height in "U"
-------------------	------------------	--------------	---------------

**23011**



**23011-012**

Model No. of Wallmount	running Part No.	Depth in 500mm	Height in "U"	Color for ordering
------------------------	------------------	----------------	---------------	--------------------

Construction Overview.....	Page I3~I4
Menu of fixing on the wall.....	Page I5~I6
D.I.Y. Menu.....	Page I7
Standard Accessories .....	Page I8
Optional Accessories.....	Page I9
Multi-installation Technical.....	Page I10~I12
Product in Detail.....	Page I13~I18

Color choose : Fill number 5, 1 in the   
 5 - RAL7035  Beige  
 1 - RAL9011  Black

(2) Component shelf



**882129-419**

Finished Part No.	running Part No.	Depth in 400mm	Height in "U"	Color for ordering
-------------------	------------------	----------------	---------------	--------------------

## CLM2305x Series Prtodution (See Page I19~I30)

**23050**



**23050-312**

Model No. of Wallmount	running Part No.	Depth in 300mm	Height in "U"	Color for ordering
------------------------	------------------	----------------	---------------	--------------------

**23051**



**23051-312**

Model No. of Wallmount	running Part No.	Depth in 300mm	Height in "U"	Color for ordering
------------------------	------------------	----------------	---------------	--------------------

(1) L-shaped mounting angle



**612079-06**

Finished Part No.	running Part No.	Height in "U"
-------------------	------------------	---------------

**23052**



**23052-312**

Model No. of Wallmount	running Part No.	Depth in 300mm	Height in "U"	Color for ordering
------------------------	------------------	----------------	---------------	--------------------

**23053**



**23053-312**

Model No. of Wallmount	running Part No.	Depth in 300mm	Height in "U"	Color for ordering
------------------------	------------------	----------------	---------------	--------------------

Construction Overview.....	Page I3~I4
Multi-installation Technical.....	Page I19
Optional Accessories.....	Page I20~I22
Product in Detail.....	Page I23~I30

Color choose : Fill number 5, 1 in the   
 5 - RAL7035  Beige  
 1 - RAL9011  Black

## CLM232x Series Prtodution (See Page I31~I53)

(1) G-shaped mounting angle



**23250-12AA**

Model No. of Wallmount	Depth in 500mm	Height in "U"	running Part No.	Color for ordering
------------------------	----------------	---------------	------------------	--------------------



**23250-12AB**

Model No. of Wallmount	Depth in 500mm	Height in "U"	running Part No.	Color for ordering
------------------------	----------------	---------------	------------------	--------------------



**612615-06**

Finished Part No.	running Part No.	Height in "U"
-------------------	------------------	---------------

Color choose : Fill number 5, 1 in the   
 5 - RAL7035  Beige  
 1 - RAL9011  Black

Construction Overview.....	Page I31~I32
Product Overview.....	Page I33
Menu of fixing on the wall.....	Page I34~I35
D.I.Y. Menu.....	Page I36~I37
Standard Accessories .....	Page I38~I41
Extension Accessories.....	Page I42
Multi-installation Technical.....	Page I43~I44
Product in Detail.....	Page I45~I53

# 19"/10" Wallmount Rack for Distributor & Under-Desk MiniServer Solutions

**CLM-23011-xxx**



**CLM-23020**

**CLM-23021**

**CLM-2305x**

**CLM-2305x**

# CLM-2301x Series OverViews

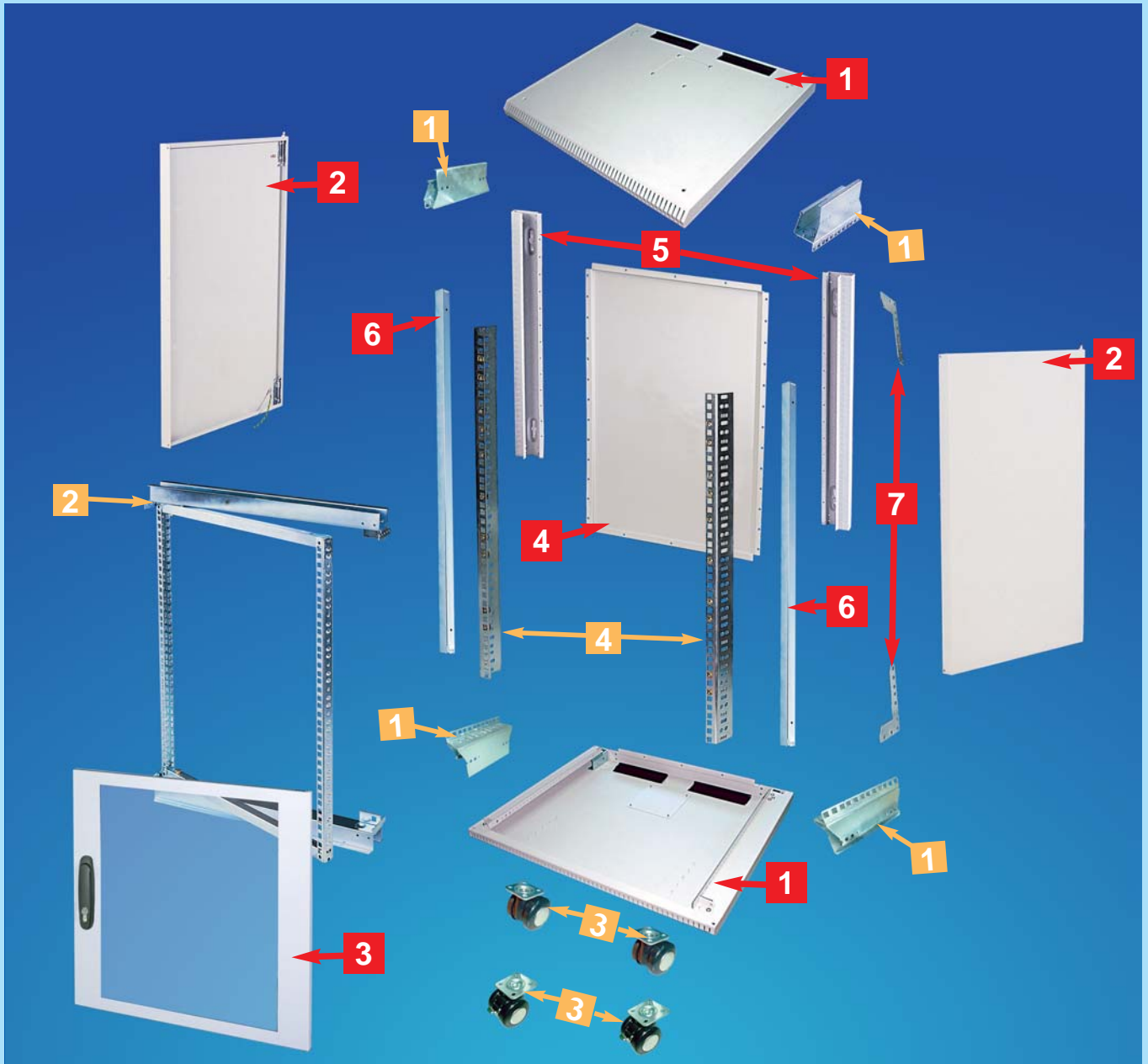

19" / 10" WALLMOUNT RACK



# CLM-2301x Series Overviews

## 19" Wallmount Rack for Distributors & UnderDesk Mini Server

page

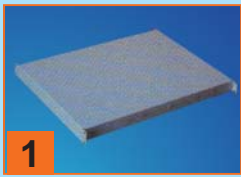

1



10



19



2



11



20

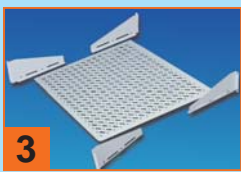

3



12



21

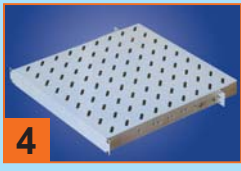

4



13



22



5



14



23



6



15



24



7



16



25



8



17



26



9



18



27

### Standard Equipments: (Included)

1. CLM-612401-xx Roof & Bottom Panel
2. CLM-612404 Side Panels
3. CLM-882163 Front Door
4. CLM-612413 Rear Panel
5. CLM-612402 Fixing Strips
6. CLM-882134 Supprt Angles
7. CLM-612409 Corner Supporter

### Extension Accessories : (Optional)

1. CLM-882079-00 CLM-23010-xx Guide Frame..... 18
2. CLM-882086-xxCLM-23011-xx 19" Swing mounting frame.... 18
3. CLM-662068-50 Twin castors, ..... 19  
CLM-662068-50sTwin castors, ..... 19
4. CLM-882083-xx L-shaped mounting Angle ..... 18
5. CLM-612011-23xx U-shaped mounting Angle..... 18
6. CLM-882038-23xx R-shaped mounting Angle..... 18
7. CLM-882085-00 Advanced hinge design. .... 112
8. CLM-882125-00 CLM-2301xx cable clamp rail..... 19
9. CLM-882089-00 cable shunting strips..... 19

### General Accessories(Optional)

1. CLM-882033 Overlapped Component shelf..... K1
2. CLM-882026 Adjustable Component shelf..... K1
3. CLM-882060 Vented & adjustable Component shelf ..... K1
4. CLM-882104 Vented Fixed Component shelf..... K2
5. CLM-882105 Vented Twin-arm Component shelf..... K2
6. CLM-882025 Telescopic slide rails Slide-in Component shelf..... K2
7. CLM-882030 Drawer 1U,2U,3U..... K2-K3
8. CLM-882103 Fixed support Angle component shelf..... K2-K3
9. CLM-612027 Sheet steel blanking panels..... E64  
CLM-612001 Aluminum blanking panels..... K18
10. CLM-312002-17/30 Earth straps..... K18
11. CLM-512007 Cable wiring duct..... K29
12. CLM-612199 Cable shunting rings,steel..... K21
13. CLM-882054 3 Sections server rail with Brackets ..... K19  
CLM-882053 3 Sections server rail with Brackets ..... K9-K17  
CLM-882052 2 Sections server rail with Brackets..... K9-K17  
CLM-882051 2 Sections server rail with Brackets..... K9-K17
14. CLM-612030 Cable clamp rails..... K20
15. CLM-958 14"/15" monitor enclosure..... K3  
CLM-950 17"monitor enclosure..... K3
16. CLM-882061 Power Socket strip & mounting bracket..... K30
17. CLM-612274 Patch panels..... K22-K27
18. CLM-882066 Cable gland panel..... K19-K20
19. CLM-911/2 Keyboard drawer with keyboard with mouse with  
Telescopic slide rails..... K4
20. CLM-662097 Swelling Boon-Bolt hinger..... K37
21. CLM-662068 Castor..... K31  
CLM-662031 Leveling foot..... K37
22. CLM-882129 Component shelf..... I9
23. CLM-882142 Cabling management strip..... K20
24. CLM-882199 Cable shunting rings strip..... K19
25. CLM-662009 Shelf-tapping washers screw..... K33-K40
26. CLM-882003 Cage Nuts..... K33-K40
27. CLM-612054 Support slide rails..... E64
28. CLM-882089 Cable shunting ring strip..... I9-1
29. CLM-882138-xxx Cooling fan..... K41



28



29

# Enjoy the scenery in CLM Wallmounted & Under-Desk Stand RACK

## Features:

- Versatility plus & quality tue CLM-2301x series with high quality & design enclosures technology with 50mm single-pane for security cooling components a wide view
- Equipped 2 spring-load pins on every panels to construct together to become a removable Modular Rack
- A swing-handle key-lock for protecting all components installation and accesories for security
- Human nature design and technology stamping with mass-produceed are able to achieve high qualiyy at competitive price & just in time deivery
- Removable design for quick "D.I.Y." assembly and freght-cost and do a good warehouse antrol
- 2 Strengthened hinger plate for mounting on wall stability
- For a under-desk mini server solution to extra order castors flexible moving on floor whilst to fixing components

"D.I.Y." Exporting package for saving long distance Importing & transportation cost

## Fixing on wall by fasten-hinger



### Swing to Right

Releasing door Left side axis hinges top & bottom can rotate this distributor easily from left to right for installation from rear-left side.



### Swing to Left

Releasing door right side axis hinges on top & bottom can rotate this distributor easily from Right to left for installation from rear-right side

### Technical 1. Swelling Boon Bolt screw fixing



Using Swelling Boom Bolt screw to bore through 4 fastened holes of panel to hinge CLM-23012-xxx Rack on wall to achieve a swing function for removing installed or replacing equipment

### Technical 2. Hinge fastener fixing

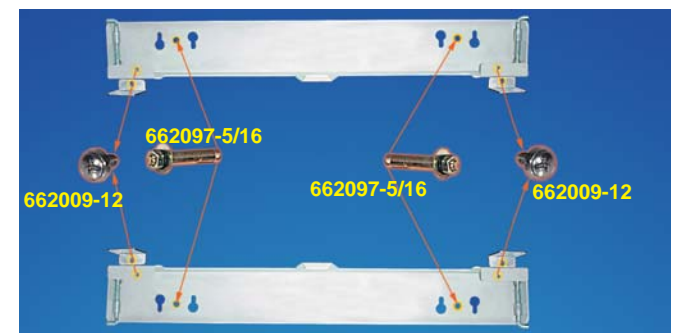

Using a strengthened stamping heavy plate be a hinge-fastener to bore on wall through swelling Boon Bolt screw to hinge CLM-2301x Series Rack on wall to achieve a swing function for removing installed or replacing equipment



# CLM-2301x Series 19" Wallmount Rack for Distributor & Under Desk Mini Server Solutions

Technical 3. Spring-loaded PIN



To pull-up(down) spring-loaded pin on left side



To releasing(fixing) screws of plated-hinger on Left side



Technical 4. Spring-loaded PIN



To pull-up(down) spring-loaded pin on Right side



To releasing(fixing) screws of plated-hinger on Right side

## Optional Accessory for Under Desk Mini Server



882145-xxx



66009-10

882003



To do Extra order fan and brushes for completing a system Rack to reach a good ventilation environment ,2 brushes for cable entries



A completed under-desk mini server system Rack with a. fans b.brushes c.castors d.swing-handle security key-lock



CLM662068-50



CLM662068-50S(Bracker)



CLM662132-00 CLM662131-00

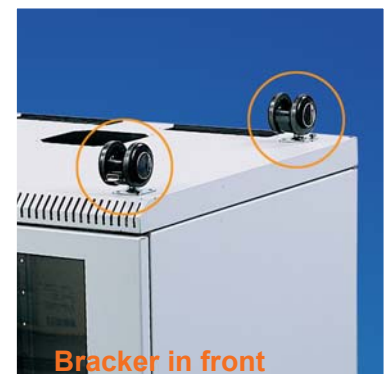

Bracker in front

To extra order castors for easily moving to exnywhere (See page No. K31)

19" /10" WALLMOUNT RACK

# CLM-2301x-xxx "D.I.Y." Operation



Decomposition view

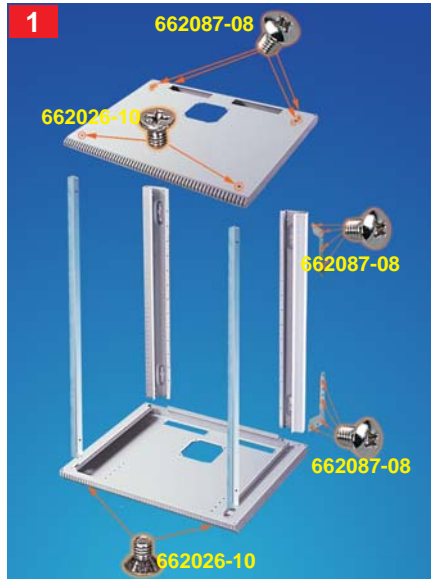

Step1. Main Construction



Step1-1.  
To aim Top cover and mounting angle



Step1-2.  
To fixing screw in mounting angle



Step1-3. fixing internal screws



Step1-4. fixing screws



Step1-5. fixing screws



Semi - assembly Rack



All door(panel) removable



Step2-1. Rear door  
To fixing screws CLM-662087-08 in every punched holes



Step 2-3~2-5 Front door  
To pull and adjust spring-loaded pins on the door into hollow on the top cover & Bottom corner to complete a CLM-2301x-xxx



Completely view

See page No. 113~118

# Standard Accessories for 2301x-xxx

## L-shaped mounting angle for 19" CLM-2301x-xxx



The Short "L-Shaped" mounting angles are punching on a "U" pitch pattern in square holes on a 25mm DIN43660 pitch pattern Direct Attached to 600mm Rack's main frame for mounting slide-in 19" Rack mounted components.  
Comes with 2 or 3 pair of depth stays on right & left side adjustable for irregular length 19" Rack mounted components

**Material:** sheet steel  
**Supply Included:** 1. 4 pcs mounting angles  
2. Assembly parts  
**Finished:** Zinc Plated

CLM Model No.	U	SU	Height mm
882083-2306	6	10	327
882083-2309	9	16	460.5
882083-2312	12	21	593.8
882083-2315	15	26	727.2
882083-2318	18	32	860.5
882083-2321	21	37	993.9
882083-2324	24	42	1127.2

## R-shaped mounting angle

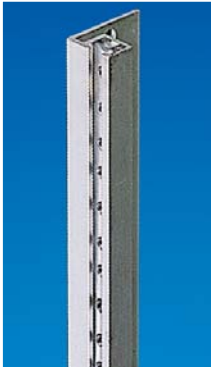

**Material:** Aluminum  
**Supply Included:** 1. 4 pcs mounting angles  
2. Assembly parts  
**Finished:** AnOdzied

The Short "R-Shaped" mounting angles are extruded Aluminum section punchings on a "U" pitch pattern has round holes integrated Two strip rails section are punched 3 holes in 1U pitch pattern & M6 tapped screw thread for front & Rear side mounting Direct attached to 600mm cabinet's main frame for mounting 19" Rackmounted components.  
Comes with 2 or 3 pair of depth strays on right & left side adjustable for irregular length 19" Rackmounted components

CLM Model No.	U	SU	Height mm
882038-2306	6	10	327
882038-2309	9	16	460.5
882038-2312	12	21	593.8
882038-2315	15	26	727.2
882038-2318	18	32	860.5
882038-2321	21	37	993.9
882038-2324	24	42	1127.2

## Guide Frames for Mounting 19" Component on CLM-23010-12

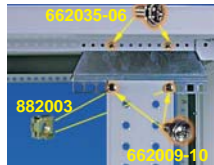

**Technical:**  
To fixing 4 pcs Guide frame on each end-side for transferring 19" standard can mounting 19" components in vertical to extend become a useful equipment.

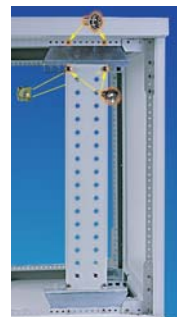

CLM Part No.	Sole Height	Pack No.	For Model No.
882079-00	4U	2	CLM-23010-12

**Material:** sheet steel  
**Supply Included:** 1. 2 pcs 1 CLM-612410-00 or CLM-612079 Guide frame Mounting angle  
2. 10 pcs CLM-882003-06 Cage Nuts  
3. 10 pcs CLM-662009-12 M 12L Washer screw  
4. Assembly parts  
**Finished:** Zinc-Plated

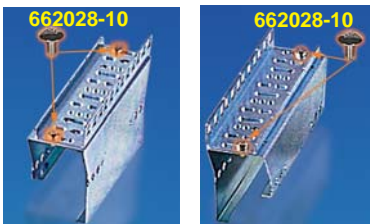

## Swing Mounting Angles



This swing Angles design for mounting 19" equipment and for optimum rear access to 19" components when installed in a fixed position the remaining free space at the sides for removing or replacing any component without ripleasing a full Rack.

**Material:** sheet steel  
**Supply Included:** 1. 2 CLM-612418-xx Top/Bottom fasteners  
2. 2 CLM-612419-xx Swing Mounting frames  
3. 2 CLM-612412-xx Swing fasteners  
4. 2 CLM-612411-xxxx Ride Brackets  
5. 2 CLM-612424-xxxx Swing Bracket  
6. 2 CLM-612425-xxxx Swing Bracket  
7. Assembly parts

CLM Part No.	Length	Pack No.	For Model No.
882086-xxx	19"	1	CLM-23011-xxx

**Pended No:** Taiwan 00910811, 90305282  
Patent Pended in US, Germany, China

**Finished:** Zinc-Plated



# Option Accessories for CLM-2301x Series

## Cable Shunting Strips , 1U



A multi-punched pitch pattern holes brackets for setting a lot of cable shunting rings to do a good cabling management control against mixing situation  
For mounting on 1 or 2 pair of 19" (482.6mm) mounting angles.

**Material:** Sheet Steel

**Supply Includes:** 1. 1 CLM-612222-55 Vented cable strip  
2. Assembly parts

**Finished:** Powder Coating in color RAL 7035 or RAL 9011

CLM Part No.	Size Inch	Pack No.
882089-55	19"	1



Fixed Power socket strip



Fixed Cable shunting ring strip

See page No. K19

## Adjustable Component shelf 1U, for 400/500mm Depth Rack

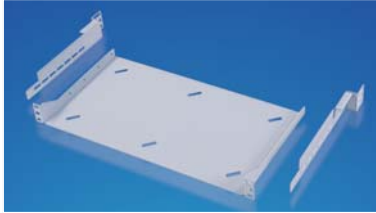

CLM Part No.	Width mm	Plate depth	Pack No.	For Model No.
882129-319	19"	150-520	1	CLM-23011-xx
882129-419	19"	250-520	1	CLM-2301x-4xx
882129-619	19"	450-520	1	CLM-2301x-5xx

**Material:** sheet steel

**Supply Includes:** 1. 1 CLM-612422-x19 Plate  
2. 1 CLM-612430-10 Left Bracket  
1 CLM-612430-20 Right Bracket  
3. Assembly parts

**Finished:** Powder Coating in Color RAL 7035, RAL 9011

For mounting between 1 or 2 pair of 19" (482.6mm) mounting angles.

4-bracket design reduces overlap area under component increases heat-dissipating ability.

## Active Cooling fan set 1U

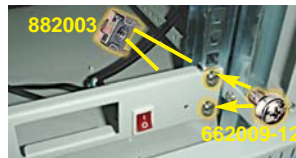

CLM Part No.	Length	Pack No.	For Model No.
882145-xxx	19"	1	CLM-2301x-xxx

To extra order a 12cm cooling fan to make a big air flow condition through a ON/OFF switch has fixing on a 19" strip to create a good ventilation environment throughout in the cabinet for mounting on the top or bottom area.

**Material:** Sheet Steel

**Supply Includes:** 1. 1 CLM-612221-00 1U Cutout plate  
2. 1 CLM-241 I/O switch with Red Button  
3. 1 CLM-312016-75 power socket with cable 750Lmm  
4. 1 CLM-312013-00 Wire-cable(see page of K41)  
5. 1 CLM-612104-12 Fan Guard(see page of K41)  
6. 1 CLM-272001-15/23 115V/230V Fan(see page of K41)  
7. Assembly parts

**Finished:** Powder Coating

## Cable clamp rail ,1U

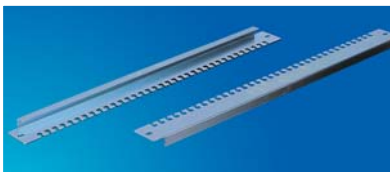

The cable may be routed at any side of the network Cabinet , or open racks Wallmount-Rack using cable ties line For system requirements.

**Material:** Sheet Steel

**Supply Includes:** 1. 1 CLM-612420-01 Vented Cable strip  
2. Assembly parts

**Finished:** Zinc-plated

CLM Part No.	Pack No.	For Model No.
882125-00	1	CLM-2301x-xxx



## Twin castors for CLM-2301x-xxx



**Bracker castors in Front**  
To use castor for removing stand server on floor

CLM Part No.	Brake Device	Pack No.
662068-50	NO	2
662068-50S	Yes	2

For problem-free location changes.

**Load capacity per castor:** 50kg static load Overall height 65mm

# CLM-2301x Series Multi-installation Technical

for predominantly passive components Advanced mini server equipment on wall or floor

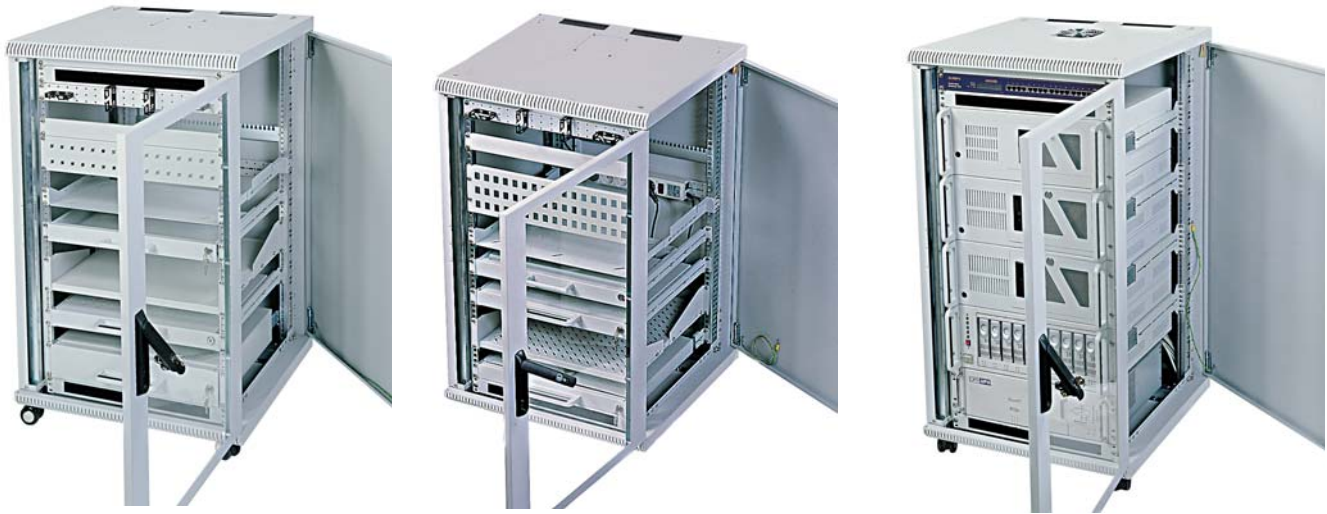

## Data Drawer 1U, 2U, 3U for 600mm Depth Rack

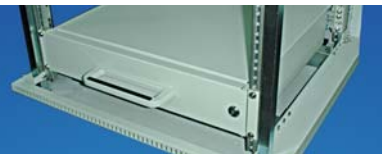
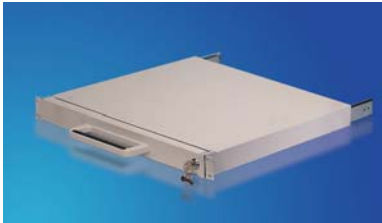

CLM Part No.	Height	Clearance Size	
		Width	Depth
882030-00	1U	448.2mm	400mm
882031-00	2U	448.2mm	400mm
882032-00	3U	448.2mm	400mm

Bracket part No. see page No. of K2

For front fixing on 482.6mm(19") mounting angles.  
With cover and telescopic slide rail to accommodate assignments Data, CD-ROM, FDD, Components & Assembly tools with key-Lock.

**Material:** Sheet Steel I.E. Series

**Finish:** Powder coating in Color RAL7035 RAL9011

## Vented Adjustable Component shelf 2U for 600mm Depth Rack

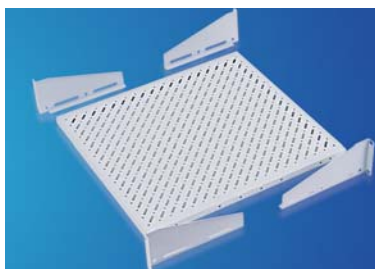

Adjustable Brackets for different Depth mounting Angles



Assembly Technical:

CLM Part No.	Width mm	Plate depth	Packs No.	For Model No.
882060-619	19"	430-630	1	CLM-23012-6xx

For mounting between 1 or 2 pairs of 482.6mm (19") mounting Angles. 4-bracket design reduces overlap area under component punched dense holes to create high heat-dissipation effect. May be inserted stand-off spacer to protect components to fall-down

**Load capacity:** 25 kg surface load, static

**Material:** sheet steel

**Supply Includes:**

4 adjustable mounting brackets & assembly parts.

**Finished:** Powder coating in Color RAL7035 RAL9011



# CLM-2301x Series Multi-installation Technical

## Component shelf 1U with 2 Sections Telescopic Slide rail for components

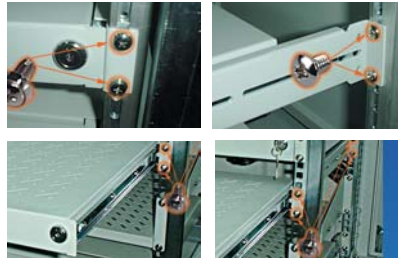

CLM Part No.	For Version of Rack	Pack No.	For Model No.
882025-06	600X600	1	CLM-23012-6xx

**Load capacity:** 25kg surface

**Material:** sheet steel

**Supply includes:**

- 1 Vented shelf integrated a pair of 2 Sections Telescopic rails set.
2. Assembled a handle & Lock.

**Finished :** Powder coating in Color RAL7035 & RAL9011

Reference to page No. of K2



For mounting between 2 pairs of 482.6mm(19") mounting angles.  
Vented shelf integrated a pair of Telescopic slide rail design provides smooth touch & convenience.



## Keyboard Drawer ,1U With Mouse PAD plate

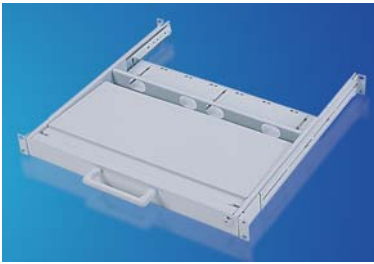

- CLM-9101 Keyboard drawer only
- CLM-9101-1 Keyboard drawer & IPC keyboard.
- CLM-9101-2 Keyboard drawer, IPC keyboard & mouse set.
- Adjustable internal slider for accommodating different Length keyboard.
- Telescopic slide Rail assembled on both sides.
- Lockable (in front)
- Dimension: 482.3x355.6x44.45mm(WxDxH)
- Internal dimensions for keyboard  
W: 424mm(MAX)  
D: 130mm(min), 252mm(max)  
H: 43mm(MAX)
- Keyboard demision: 424x130x40mm(WxDxH)MAX

CLM Part No.	IPC keyboard	LIBRA TRACKBALL	Mouse	For Model No.
CLM-9101	X	X	X	CLM-23012-6xx
CLM-9101-1	·	X	X	CLM-23012-6xx
CLM-9101-2	·	X	·	CLM-23012-6xx

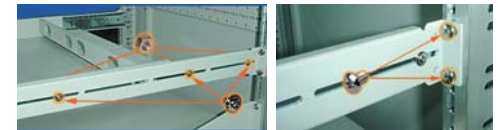

With Key-Lock for General component placing keyboard

Reference to page No. of K4 for more in detail



- Shipping dimensions:  
1PC/CTN/1.47 CUFT
- N.W: 4.8kgs(with KBD)
- G.W: 5.9kgs(with KBD)
- Color :RAL7035 RAL9011



## Adjustable Component shelf 2U, for Monitor. Ups. Components

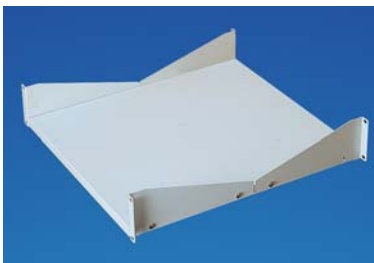

CLM Part No.	Width mm	Plate Depth	Packs No.	For Model No.
882026-619	19"	430-630	1	CLM-23012-6xx

For mounting between 1 or 2 pairs of 482.6mm (19") mounting angles. 4-bracket design reduces overlap area under component increases heat-dissipating ability. for place general components I.E. Ups Monitor, HUB, KVM, Vedio....Etc  
Adjustable Bracket for different depth Mounting Angles

**Load capacity:** 25 kg surface load, static

**Material:** sheet steel

**Supply Includes:**

1. Flat shelf & 4 adjustable Brackets
2. Assembly parts

**Finished :** Powder coating in Color RAL7035 RAL9011

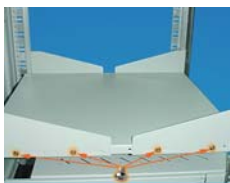



# CLM-2301x Series Multi-installation Technical

## Advanced hinge Fastener



A strengthened stamping heavy plate to provide for stability hinger with havey loads capacity for the swing Rack



### Swing to Right(or Left)

90° Releasing door right side axis hinges on top & bottom & you can rotate this distributor easily from left to right.

CLM Part No.	Pack No.	For Model No.
882085-00	1	CLM-2301x-xxx

**Material:** Heavy Sheet Steel

**Supply Included:** 1. 2 CLM-612416-03 strengthened stamping-plate  
2. 2 CLM-612417-00 hinge Brackets  
3. Assembly parts

**Finished:** powder coating in color RAL7035 or RAL9011

## 2 , 3 Sections Server Rail with Mounting Bracket

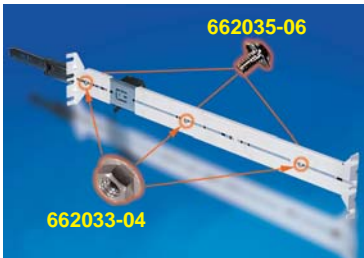

These server rails can be mounted in all-600mm length Rack with two pair of mounting angles through brackets for server system rails & mounting onto the Cabinet that Telescopic slide rail provides a smooth reliable & convenience operation. For replacing or repairing any component of server system in efficiency

**Supply includes:**

1. a pair of Telescopic Rail
2. 2 pair of rail Brackets
3. Assembly parts

**Material:** Sheet steel

**Finished:** Zinc-Plated for slide rail  
Powder Coating for rail Brackets in RAL7035 or RAL9011



**See CLM SYSTEM ACCESSORIES**  
see page of K-7 ~ K-15

## 8U, 14" or 15" monitor Enclosure



For installation 14" or 15" monitor Monitoring moving out or dropping down from the Rack Between a pair of mounting Angles.

Mounting into the CLM-2301x Rack with a CLM-912

- "D.I.Y." TYPE
- REVOLVING CONTROL PANEL
- REMOVABLE & ADJUSTABLE BASE FRAME
- 3 SETS ADJUSTABLE MOUNTING BRACKETS for AGAINST VIBRATION.
- SHIPPING DIMENSIONS:  
1PC/CTN1.2CUFT
- N.W:5.5KGS
- G.W:7.8KGS

**Supply Includes:** assembly parts.

**Material:** sheet steel

**Finished:** powder coating in color RAL7035 or RAL9011



CLM Model No.	U	Pack No.	For Model No.
CLM-958	8	1	CLM-2301x-5/6xx

**Patent Pended No:** 189471 Taiwan  
20104717.9 Germany  
09/816,332 USA  
01208311.9 China

# CLM-23010 ■ Wallmount & Under-Desk Rack Series

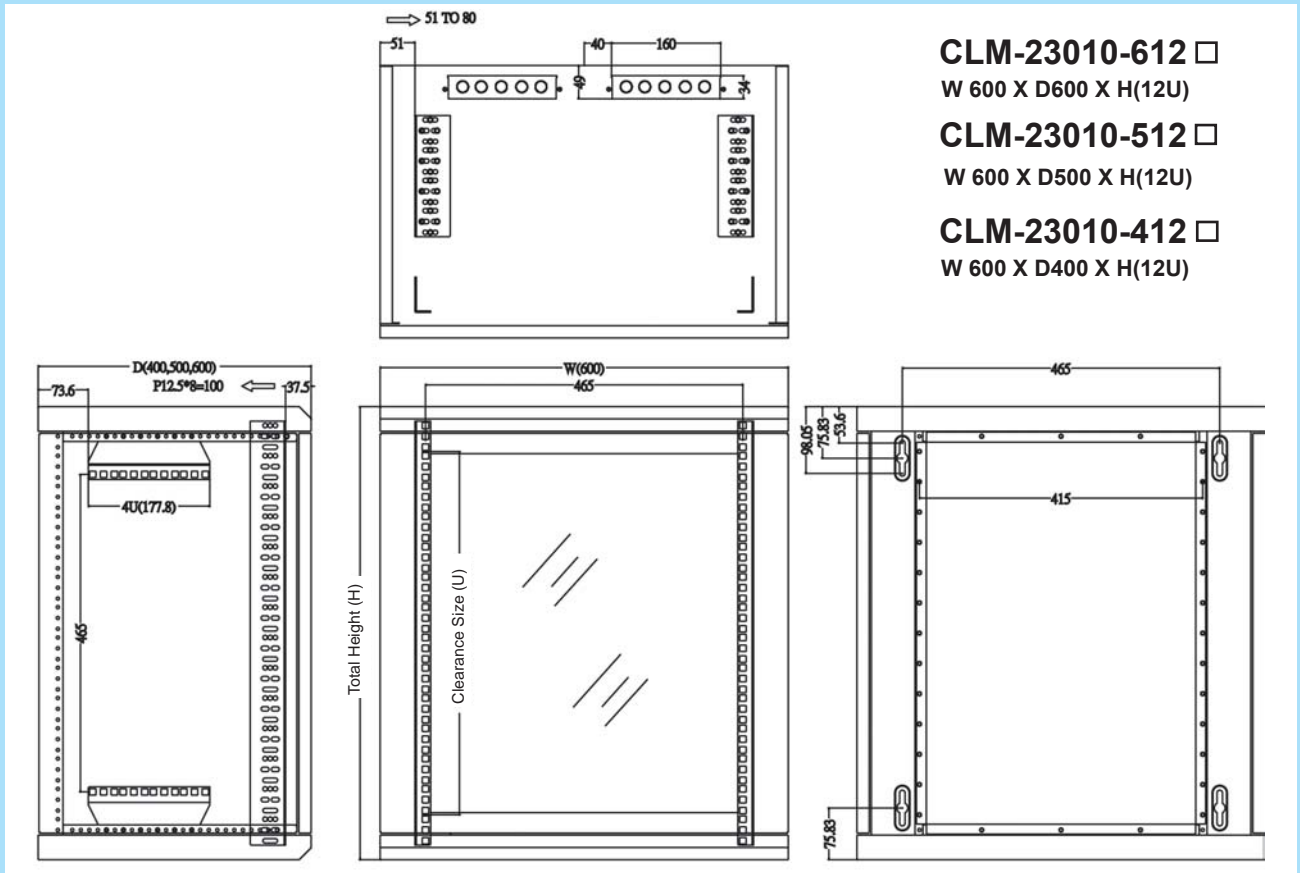

**CLM-23010-612** □  
W 600 X D600 X H(12U)

**CLM-23010-512** □  
W 600 X D500 X H(12U)

**CLM-23010-412** □  
W 600 X D400 X H(12U)

## Specification Comparative table:

Model No. CLM-	23010-412 □	23010-512 □	23010-612 □
Total Unit (U)	12	12	12
Total Height (H)	665.05	665.05	665.05
Width (W)	600	600	600
Depth (D)	400	500	600
Clearance Size (U) 1U=44.45mm	533.4	533.4	533.4
Shipping Dimension(complete):	8.45	10.23	12.01
Shipping Dimension(D.I.Y.):	4.70	5.03	5.62
G.W.:	21.13	23.39	30.28

Standard Accessories(Included):	Pack No.
1. CLM-662009-00 Self-tapping washer screw, M6 X 12mm See page No. K34	25
2. CLM-882003-06 Cage nut M6 See page No. K39	25
3. CLM-882079-00 Guide Frame See page No. I 8	2

Option Accessories	Pack No.
1. CLM-882085-00 Wall-mounted hinge Fastener See page No. I 12	2
2. CLM-882089-55 1U, Mounting panel See page No. I 9	1
3. CLM-882125-00 Cable clamp rails, 600 mm See page No. I 9	4
4. CLM-662097-5/16 Swelling Boom Bolt screw See page No. K37	4
5. CLM-662068-50/50S Twin Castors See page No. I 9	4
6. CLM-312009-05 Power Socket strips, GB 16A / 230V See page No. K30-K34	1
7. CLM-312008-06 Power Socket strips, USA 15A / 125V See page No. K30-3	1
8. CLM-882129-00 1U Component shelf , for 19" width See page No. I 9	1
9. CLM-612199-00 Cable shunting ring, steel-made ( H80 X W40 X D23 ) See page No. K19-1 for 882199	10
10. CLM-612027 Blanking panel (sheet steel) See page No. K18-1	2
11. CLM-612001 Blanking panel (sheet aluminum) See page No. K18-4	2
12. CLM-882145-xxx Cooling Fan set See page No. I9	1
13. CLM-312002-xx Earth straps See page No. K29	5

Color choose : Fill number 5, 1 in the □

5 - RAL7035

1 - RAL9011

# CLM-23010 19" WALL-MOUNT Rack

For Distributors & Under-Desk Mini Server Solutions



"D.I.Y" shipping package available



### Standard Mechanism (Included):

- Material : Sheet Steel by strengthened stamping skills
- Front Door : 1 pc CLM-882163-00 Sheet Steel Frame with 3.0mm thickness strengthened glass with swing handle security Key-Lock, Removable.
- Rear door : 1 pc CLM-882082-00 ,fixed 2 pcs CLM-612402 strips Removable
- Side panels: 2 pcs CLM-882073-00 swing Design, with 2 pcs CLM-312002 Earth straps ,Removable
- Roof & Bottom(plinth): Vented 2 pcs CLM-612401-xx mounted 4 pcs CLM-612409 corner supporters, with 2 cable entries with brush strips & 1 Fan cutout ,Removable
- Support Angle : 2 pcs CLM-882134 in "U" Shaped Steel pipes
- Mounting Angle : 2 pcs CLM-882083-00 L-Shaped, Zinc-plated.
- Guide Frame: 2 pcs CLM-882079-00 for mounting 19" components on left or right side through 4 pcs CLM-612079 transfer Bases. (See page No. 18)
- Finished : Powder coating in color RAL 7035 or RAL 9011



### Pended No:

Taiwan 187825 , 053457 , 081293 , 91213894  
China ZL01342906.X  
USA 6,467,640B1, D463,794S, 10/364,335  
Germany 20111765.7 , 40108331.4

19" / 10" WALLMOUNT RACK



# CLM-23011 ■ Wallmount & Under-Desk Rack Series

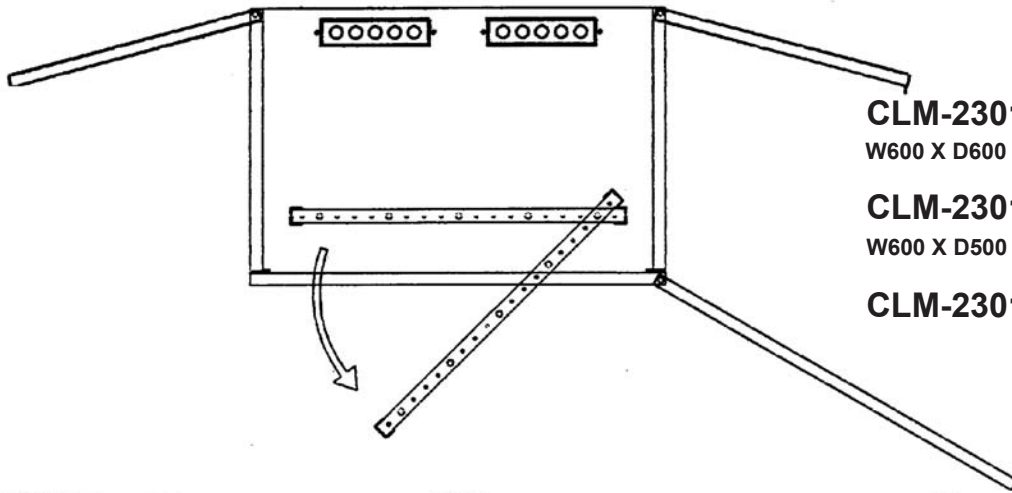

**CLM-23011-612** □  
W600 X D600 X H(12U to 24U)

**CLM-23011-512** □  
W600 X D500 X H(6U to 24U)

**CLM-23011-412** □

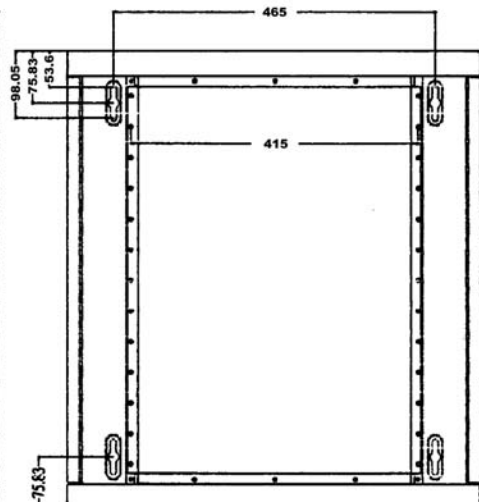
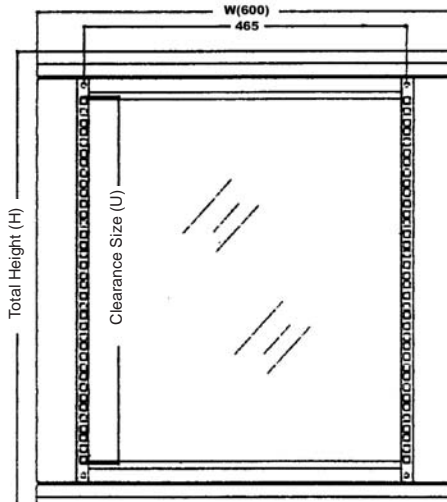
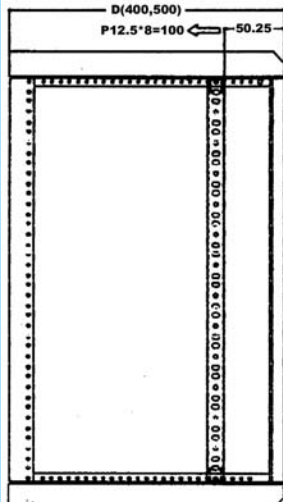

## Specification Comparative table:

Model No. (for D=400mm) CLM-	23011-406 □	23011-409 □	23011-412 □	23011-415 □	23011-418 □	23011-421 □	23011-424 □
Model No. (for D=500mm) CLM-	23011-506 □	23011-509 □	23011-512 □	23011-515 □	23011-518 □	23011-521 □	23011-524 □
Model No. (for D=600mm) CLM-			23011-612 □	23011-615 □	23011-618 □	23011-621 □	23011-624 □
Total Unit (U)	6	9	12	15	18	21	24
Total Height (H)	398.35	531.7	665.05	798.4	931.75	1065.1	1198.45
Width (W)	600	600	600	600	600	600	600
Depth (D) 400 / 500 / 600 :	400 / 500	400 / 500	400 / 500 / 600	400 / 500 / 600	400 / 500 / 600	400 / 500 / 600	400 / 500 / 600
Clearance Size (U) 1U=44.45mm	266.7	400.05	533.4	666.75	800.1	933.45	1066.8
Shipping Dimension(complete):	5.43/ 6.58	6.49/ 8.40	8.45/ 10.23/12.01	12.05/14.39/16.73	13.79/16.47/19.15	15.53/18.54/21.56	17.27/20.63/23.98
Shipping Dimension(D.I.Y.):	3.99/4.32	4.73/5.06	5.47/5.80/6.26	6.21/6.45/7.00	6.96/ 7.29/7.74	7.70/ 8.03/8.48	8.44/8.77/9.23
G.W.:	16.3/18.29	18.74/ 20.86	21.13/23.39/30.28	23.52/25.91/33.16	25.91/28.43/36.03	28.3/ 30.95/38.91	30.69/33.47/41.78

Standard Accessories(Included):	Pack No.
1. CLM-662009-12 Self-tapping washer screw, M6 X 12mm	See page No. K34 25
2. CLM-882003-06 Cage nut M6	See page No. K39 25

Option Accessories	Pack No.
1. CLM-882085-00 Wall-mounted hinge Fastener	See page No. I 12 2
2. CLM-882089-55 1U, Mounting panel	See page No. I 9 1
3. CLM-882125-00 Cable clamp rails, 600 mm	See page No. I 9 4
4. CLM-662097-5/16 Swelling Boom Bolt screw	See page No. K37 4
5. CLM-662068-50/50S Twin Castors	See page No. I 9 4
6. CLM-312009-05 Power Socket strips, GB 16A / 230V	See page No. K30-1 1
7. CLM-312008-06 Power Socket strips, USA 15A / 125V	See page No. K29-5 1
8. CLM-882129-00 1U Component shelf , for 19" width	See page No. I 9 1
9. CLM-612199-00 Cable shunting ring, steel-made ( H80 X W40 X D23 )	See page No. K19-1 for 882199 10
10. CLM-612027 Blanking panel (sheet steel)	See page No. K18-1 2
11. CLM-612001 Blanking panel (sheet aluminum)	See page No. K18-4 2
12. CLM-882145-xxx Cooling Fan set	See page No. I 9 1
13. CLM-312002-xx Earth straps	See page No. K29 5

Color choose : Fill number 5, 1 in the □

- 5 - RAL7035
- 1 - RAL9011

# CLM-23011 19" WALL-MOUNT Rack

For Distributors & Under-Desk Mini Server Solutions



"D.I.Y" shipping package available



### Standard Mechanism (Included):

- Material : Sheet Steel by strengthened stamping skills
- Front Door : 1 pc CLM-882163-00 Sheet Steel Frame with 3.0mm thickness strengthened glass with swing handle security Key-Lock, Removable.
- Rear door : 1 pc CLM-882082-00 ,fixed 2 pcs CLM-612402 strips Removable
- Side panels: 2 pcs CLM-882073-00 swing Design, with 2 pcs CLM-312002 Earth straps ,Removable
- Roof & Bottom(plinth): Vented 2 pcs CLM-612401-xx mounted 4 pcs CLM-612409 corner supporters, with 2 cable entries with brush strips & 1 Fan cutout ,Removable
- Support Angle : 2 pcs CLM-882134 in "U" Shaped Steel pipes
- Mounting Angle : CLM-882086 90° Swing Frame ,Zinc-Plated.
- Finished : Powder coating in color RAL 7035 or RAL 9011



### Pended No:

Taiwan 187825 , 053457 , 081293 , 91213894  
China ZL01342906.X  
USA 6,467,640B1, D463,794S, 10/364,335  
Germany 20111765.7 , 40108331.4

19" / 10" WALLMOUNT RACK

# CLM-23012 ■ Wallmount & Under-Desk Rack Series

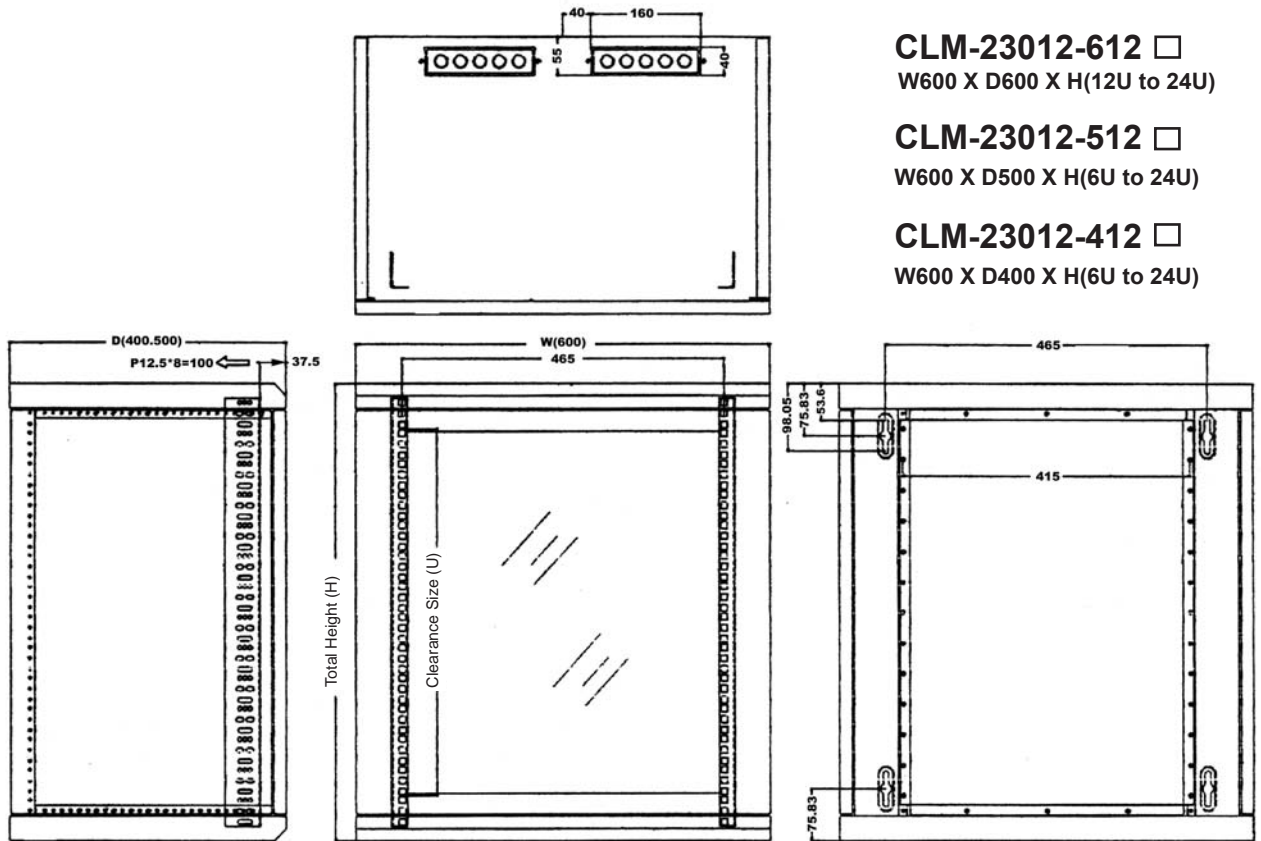

**CLM-23012-612**   
W600 X D600 X H(12U to 24U)

**CLM-23012-512**   
W600 X D500 X H(6U to 24U)

**CLM-23012-412**   
W600 X D400 X H(6U to 24U)

## Specification Comparative table:

Model No. (for D=400mm) CLM-	23012-406 <input type="checkbox"/>	23012-409 <input type="checkbox"/>	23012-412 <input type="checkbox"/>	23012-415 <input type="checkbox"/>	23012-418 <input type="checkbox"/>	23012-421 <input type="checkbox"/>	23012-424 <input type="checkbox"/>
Model No. (for D=500mm) CLM-	23012-506 <input type="checkbox"/>	23012-509 <input type="checkbox"/>	23012-512 <input type="checkbox"/>	23012-515 <input type="checkbox"/>	23012-518 <input type="checkbox"/>	23012-521 <input type="checkbox"/>	23012-524 <input type="checkbox"/>
Model No. (for D=600mm) CLM-			23012-612 <input type="checkbox"/>	23012-615 <input type="checkbox"/>	23012-618 <input type="checkbox"/>	23012-621 <input type="checkbox"/>	23012-624 <input type="checkbox"/>
Total Unit (U)	6	9	12	15	18	21	24
Total Height (H)	398.35	531.7	665.05	798.4	931.75	1065.1	1198.45
Width (W)	600	600	600	600	600	600	600
Depth (D)400 / 500 / 600	400 / 500	400 / 500	400 / 500/600	400 / 500/600	400 /500/600	400 /500/600	400 /500/600
Clearance Size (U) 1U=44.45mm	266.7	400.05	533.4	666.75	800.1	933.45	1066.8
Shipping Dimension(complete):	5.43/ 6.58	6.94/ 8.40	8.45/10.23/12.01	12.05/14.39/16.73	13.79/16.47/19.15	15.53/18.54/21.56	17.27/20.63/23.98
Shipping Dimension(D.I.Y.):	3.48/3.81	4.04/4.37	4.59/4.92/5.56	5.14/5.47/6.12	5.70/ 6.03/6.68	6.25/ 6.58/7.25	6.81/7.14/7.81
G.W.:	16.3/18.29	18.74/ 20.86	21.13/23.39/30.28	23.52/25.91/33.16	25.91/28.43/36.03	28.3/ 30.95/38.91	30.69/33.47/41.78

Standard Accessories(Included):		Pack No.
1. CLM-662009-12 Self-tapping washer screw, M6 X 12mm	See page No. K34	25
2. CLM-882003-06 Cage nut M6	See page No. K39	25

Option Accessories		Pack No.
1. CLM-882085-00 Wall-mounted hinge Fastener	See page No. I 12	2
2. CLM-882089-55 1U, Mounting panel	See page No. I 9	1
3. CLM-882125-00 Cable clamp rails, 600 mm	See page No. I 9	4
4. CLM-662097-5/16 Swelling Boom Bolt screw	See page No. K37	4
5. CLM-662068-50/50S Twin Castors	See page No. I 9	4
6. CLM-312009-05 Power Socket strips, GB 16A / 230V	See page No. K30-1	1
7. CLM-312008-06 Power Socket strips, USA 15A / 125V	See page No. K29-4	1
8. CLM-882129-00 1U Component shelf , for 19" width	See page No. I 9	1
9. CLM-612199-00 Cable shunting ring, steel-made ( H80 X W40 X D23 )	See page No. K19-1 for 882199 See page No. K19-2	10
10. CLM-612027 Blanking panel (sheet steel)	See page No. K18-1	2
11. CLM-612001 Blanking panel (sheet aluminum)	See page No. K18-4	2
12. CLM-882145-xxx Cooling Fan set	See page No. I 9	1
13. CLM-312002-xx Earth straps	See page No. K29	5

Color choose : Fill number 5, 1 in the

5 - RAL7035

1 - RAL9011



# CLM-23012 19" WALL-MOUNT Rack

For Distributors & Under-Desk Mini Server Solutions



"D.I.Y" shipping package available



### Standard Mechanism (Included):

- Material : Sheet Steel by strengthened stamping skills
- Front Door : 1 pc CLM-882163-00 Sheet Steel Frame with 3.0mm thickness strengthened glass with swing handle security Key-Lock ,Removable.
- Rear door : 1 pc CLM-882082-00 ,fixed 2 pcs CLM-612402 strips Removable
- Side panels: 2 pcs CLM-882073-00 swing Design, with 2 pcs CLM-312002 Earth straps ,Removable
- Roof & Bottom(plinth): Vented 2 pcs CLM-612401-xx mounted 4 pcs CLM-612409 corner supporters, with 2 cable entries with brush strips & 1 Fan cutout ,Removable
- Support Angle : 2 pcs CLM-882134 in "U" Shaped Steel pipes
- Mounting Angle : 4 pcs CLM-882083-00 L-Shaped ,Zinc-plated.
- Finished : Powder coating in color RAL 7035 or RAL 9011



### Pended No:

Taiwan 187825 , 053457 , 081293 , 91213894  
China ZL01342906.X  
USA 6,467,640B1, D463,794S , 10/364,335  
Germany 40108331.4

19" / 10" WALLMOUNT RACK

**Complete for small networks!**

**Feature:**

- ┆ Torsionally stiff structure of multi-folded
- ┆ Made of Sheet steel.
- Assembly-friendly solutions.
- ┆ Perfect cable entry, fast population and Wiring.
- ┆ Unlimited mounting opportunities on Every section.
- ┆ Compatible with CLM system accessories.
- ┆ Powder coating.



**Technical construction**



**ON Wall type1**

To fixing through swelling Boom Bolt screw



To release side panel(left)1



To release side panel(left)2



**Removable Design**



To release side panel(Right)1



To release side panel(Right)2



**ON Wall type2**

through hinge-fastener



**Front cable routing**  
Via Plastic Round Ring



**Ceiling side cable routing**  
Via Plastic Round Ring

**L-shaped mounting angle For 10" for CLM-2305x Series**



The Short "L-Shaped" Mounting angles are punching on a 25mm squar holes in line Direct fixing to Top & Bottom cover & side panels for mounting 10" Rackmounting components.

**Material:** Sheet steel  
**Supply Includes:**  
1. 4 pcs mounting angles  
2. Assembly parts  
**Finished:** Zinc-Plated

CLM Part No.	U	Height	For CLM Model
612079-06	4	266.7	CLM-23050/3-xx
612079-10	8	444.5	CLM-23050/3-xx
612079-14	12	622.3	CLM-23050/3-xx

# Option Accessories For CLM-2305x Series

## L-shaped cabling Routing Angle For CLM-23051-12



1 pair of "L- shaped" angles to fix in up and bottom front For transferring 19" standard components can mounting in vertical to becom a useful equipment Equipped plastic round ring cable socket for easily cable access to against cable scratched for protection a perfect accomodation system management.

CLM Part No.	Using	Pack No.	CLM Model No.
882099-00	19"	2	CLM-23051-12

**Material:** Sheet steel

**Supply Includes:** 1. 2 CLM-612451-00 L-Shaped Angles  
2. Assembly parts

**Finished:** Zinc- Plated



## S-shaped Cabling Routing Angle For CLM-23052-12 & 23053-12

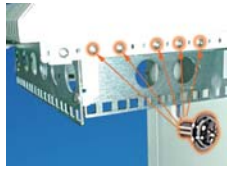

1 or 2 pair of "S-shaped" angles to fixing on two sides for mounting 19" components, patch panel in side with plastic Round cable socket for easily Access to aganist cable-scratched for protecting a perfect accomodation system equipment.

CLM Part No.	Using	Pack No.	CLM Model No.
882155-00	19"	4	CLM-23051/53-12

**Material:** Sheet steel

**Supply Includes:** 1. 4 CLM-612450-00 S-Shaped Angles  
2. Assembly parts

**Finished:** Zinc- Plated



## Fasten-Hinger For CLM-2305x series



A strengthened stamping heavy plate to provide for stability hinger with havey loads capacity for the swing Rack

CLM Part No.	SPEC	Pack No.	CLM Model No.
612443-00	10"	2	CLM-2305x-xx

**Material:** Heavy Sheet Steel

**Supply Included:** 1. 2 pcs stamping-plate  
2. Assembly parts

**Finished:** powder coating in color RAL7035 or RAL9011





# Option Accessories For CLM-2305x Series

## 1U, 10" Blanking panel

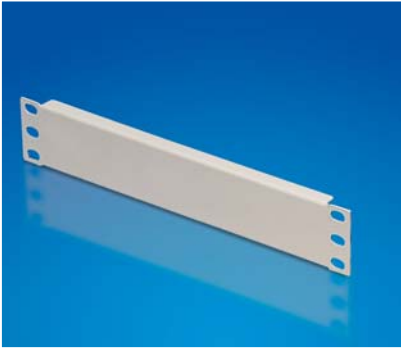

As an extension cover of for populatoin required.  
Part No. CLM-612455

**Material:** sheet steel

**Supply Includes:** Assembly parts. to be part No.882112

**Finished :** Powder Coating in RAL7305 or RAL9011

CLM Part No.	SPEC	Pack No.	For Model No.
612455-00	10"	1	CLM-2305x-xx



## 1U 10" Cable Shunting Strips



The cable may be routed at the side of rear of the network enclosure using cable ties, in line with system requirements.

**Material:** Sheet Steel

**Supply Includes:** Assembly parts. to be part No.882113

**Finished :** Powder Coating in RAL7305 or RAL9011

CLM Part No.	SPEC	Pack No.	For Model NO.
612456-00	10"	1	CLM-2305x-xx

## 1U, 10" Component shelf



For mounting 482.6mm (19") to put components on.  
Part No. 612453

**Material:** Sheet Steel

**Supply Includes:** Assembly parts.

**Finished :** Powder Coating in RAL7305 or RAL9011

CLM Part No.	SPEC	Pack No.	For Model No.
882110-00	10"	1	CLM-2305x-xx

## 1U, 10" Cable access panel



as an extension cover for cable management

**Material:** Sheet Steel

**Supply Includes:** Assembly parts. to be part No.882111

**Finished :** Powder Coating in RAL7305 or RAL9011

CLM Part No.	SPEC	Pack No.	For Model No.
612454-00	10"	1	CLM-2305x-xx

# Option Accessories For CLM-2305x Series

## 1U, 10" Cable clamp rails For CLM-2305x

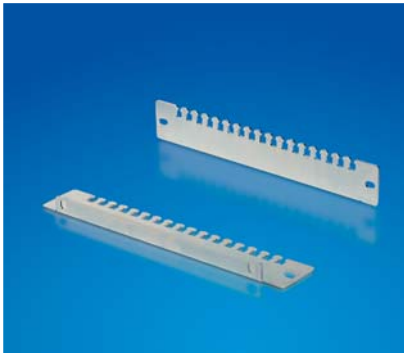

CLM Part No.	SPEC	Pack NO.	For Model No.
612452-00	10"	1	CLM-2305x-xx

Completed part No: CLM-882100

The cable may be routed at any side of the network Cabinet , or open racks Wallmount Rack using cable ties line For system requirements.

**Material:** Sheet Steel

**Supply Includes:** 662087-08 2 pcs screws  
662055-10 2 pcs screws

**Finished :** Powder Coating in RAL7305 or RAL9011

## 1U, 19" Cable access panel For CLM-2305x series



A CLM-612454 cutout panel 390 X 29 mm (1U) with brush strip for dust protection.

With accommodation facility for transferring 19" cabling clamp straps

**Material:** Sheet Steel

**Finished :** Powder Coating in RAL7305 or RAL9011

CLM Part No.	SPEC	Pack NO.	For Model No.
882066-19	19"	1	CLM-2305x-xx



## Cable Shunting Rings For all CLM-Rack



A flexible cable shunting strips may be routed on the mounting angles at any side of using cable tie in line with a system equipment. According to the cable size and volume to do a selection in shunting ring. There are some of items for routing different cable

**Material:** Sheet Steel

**Supply Includes:**

Including locating plate and fixing parts

**Finished :** Zinc-plated

CLM Part No.	For CLM Rack	Pack No.
	H X W X D mm	
612199-26	60 X 24 X 13.5	20
612199-45	50 X 40 X 13.5	20
612199-46	60 X 40 X 13.5	20
612199-48	80 X 40 X 13.5	20
612199-68	80 X 60 X 13.5	20



## SSL-1104 kvm switch controller

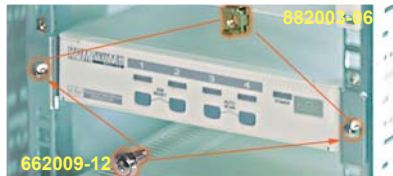

4 port KVM switch provides access to multiple computers from one keyboard, mouse and monitor. There is no interface card nor software to configure. Installation is as easy as connecting cables between 4 port KVM switch and your computers. Operation is as simple as pressing push buttons on the front panel and entering hot-key command. Hot-key function allows easy computer access. Auto scan Mode automatically selects computer sequentially. Beep sounds for switching port confirmation. LED Display present easy status monitoring.

**SSL-1104-19 :** For 19" Rack

**SSL-1104-10 :** For 10" Rack

# CLM-23050 - XXX ■ 10" Wallmount-Rack Series

**CLM-23050 - XXX □**  
**W300 X D300 X H(4U to 12U)**

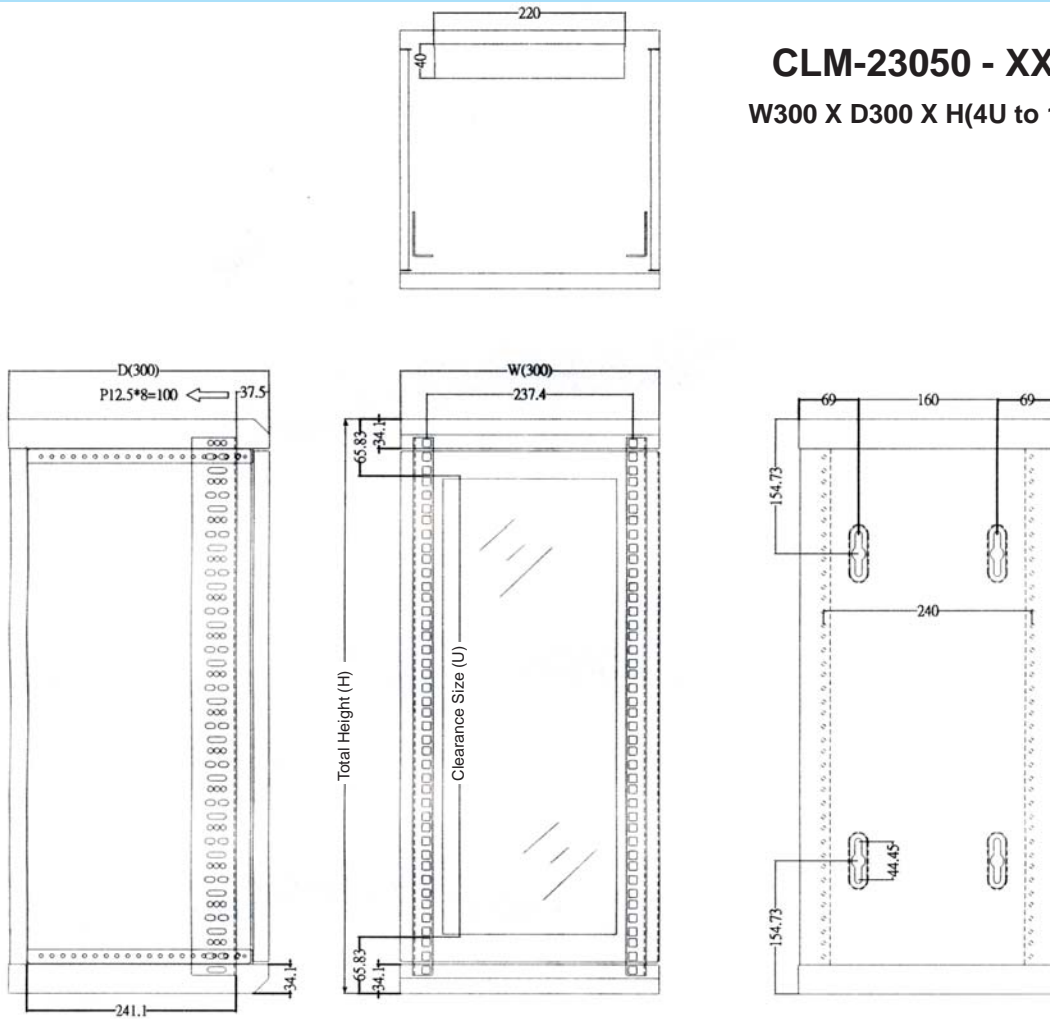

## Model No. :CLM-23050 - XXX ■ Accessories For 10" components

Model No.	23050-304 □	23050-308 □	23050-312 □
<b>Total Unit (U) :</b>	4	8	12
<b>Total Height (H) :</b>	309.45	487.25	665.05
<b>Width (W) :</b>	300	300	300
<b>Depth (D) :</b>	300	300	300
<b>Clearance Size (U) 1U=44.45mm</b>	177.8	355.6	533.4
<b>Shipping Dimension(completed):</b>	1.84	2.74	3.64
<b>G.W.:</b>			
<b>Standard Accessories(Included):</b>			<b>Pack No.</b>
1. CLM-612443-00	Wall-mounted hinge bracket	See page No. I 20	2
2. CLM-662009-12	Self-tapping washer screw, M6 X 12mm	See page No. K34	10
3. CLM-882003-06	Cage nut M6	See page No. K39	10
4. CLM-612079-00	Mounting Angles	See page No. I 19	2

<b>Option Accessories</b>			<b>Pack No.</b>
1. CLM-882100-00	Cable clamp rails, for 10" width	Part No.CLM-612452-00 See page No. I 22	1
2. CLM-882113-00	1U Cable Shunting strip	Part No.CLM-612456-00 See page No. I 21	1
3. CLM-662097-1/4	Bolt-hinger screw	See page No. K37	4
4. CLM-882110-00	1U component shelf, for 10" width	Part No.CLM-612453-00 See page No. I 21	1
5. CLM-882111-00	1U cable access panel, for 10" width	Part No.CLM-612454 See page No. I 21	1
6. CLM-882112-00	1U banking panel (sheet steel), for 10" width	Part No.CLM-612455 See page No. I 21	1
7. CLM-612199-xx	Cable shunting ring, steel-made ( H80 X W40 X D23 )	See page No. K19-1	10

Color choose : Fill number 5, 1 in the

5 - RAL7035

1 - RAL9011



# CLM-23050 10" WALL-MOUNT Rack

## For Telecom Distributor Solutions



### Technical Functions:

- For mounting cables or 10" components from front or rear side through mounting angles in Horizontal

### Standard Construction (Included):

- Material : Sheet Steel by strengthened stamping skills
- Front Door : 1 pc CLM-612445 with 3.0mm thickness strengthened glass with security Key-Lock, with 1 earth strap.
- Rear door : 1 pc CLM-612442
- Side panels: 2 pcs CLM-612444
- Roof & Bottom Panel: 2 pcs CLM-612441 vented & with 1 cable entry.
- Mounting Angles : 2 pcs CLM-612079 punch on a pitch pattern 25mm square holes in line.
- Fastener-Hinger: 2 pcs CLM-612443 punched 2 Holes.
- Finished : Powder coating in color RAL 7035 or RAL 9011
- Shipping Dimension: CLM-23050-304: 1.84 Cuft  
CLM-23050-308: 2.74 Cuft  
CLM-23050-312: 3.64 Cuft

### Pended No:

Taiwan 187825 , 0534571 , 081293 , 91213894  
China ZL01342906.X  
USA 6,467,640B1, D463,794S, 10/364,335  
Germany 20111765.7 , 40108331.4

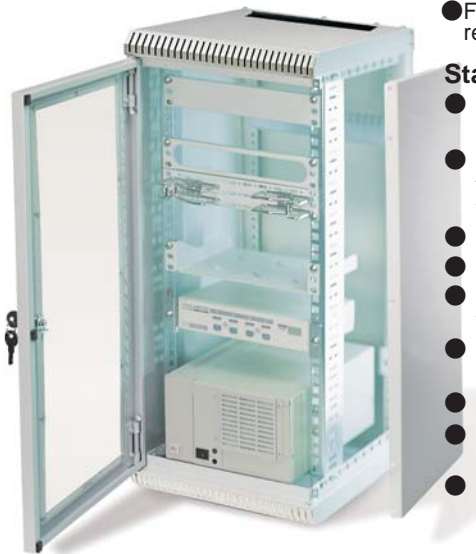

19" / 10" WALLMOUNT RACK

# CLM-23051-312 ■ 10" Wallmount Rack Series

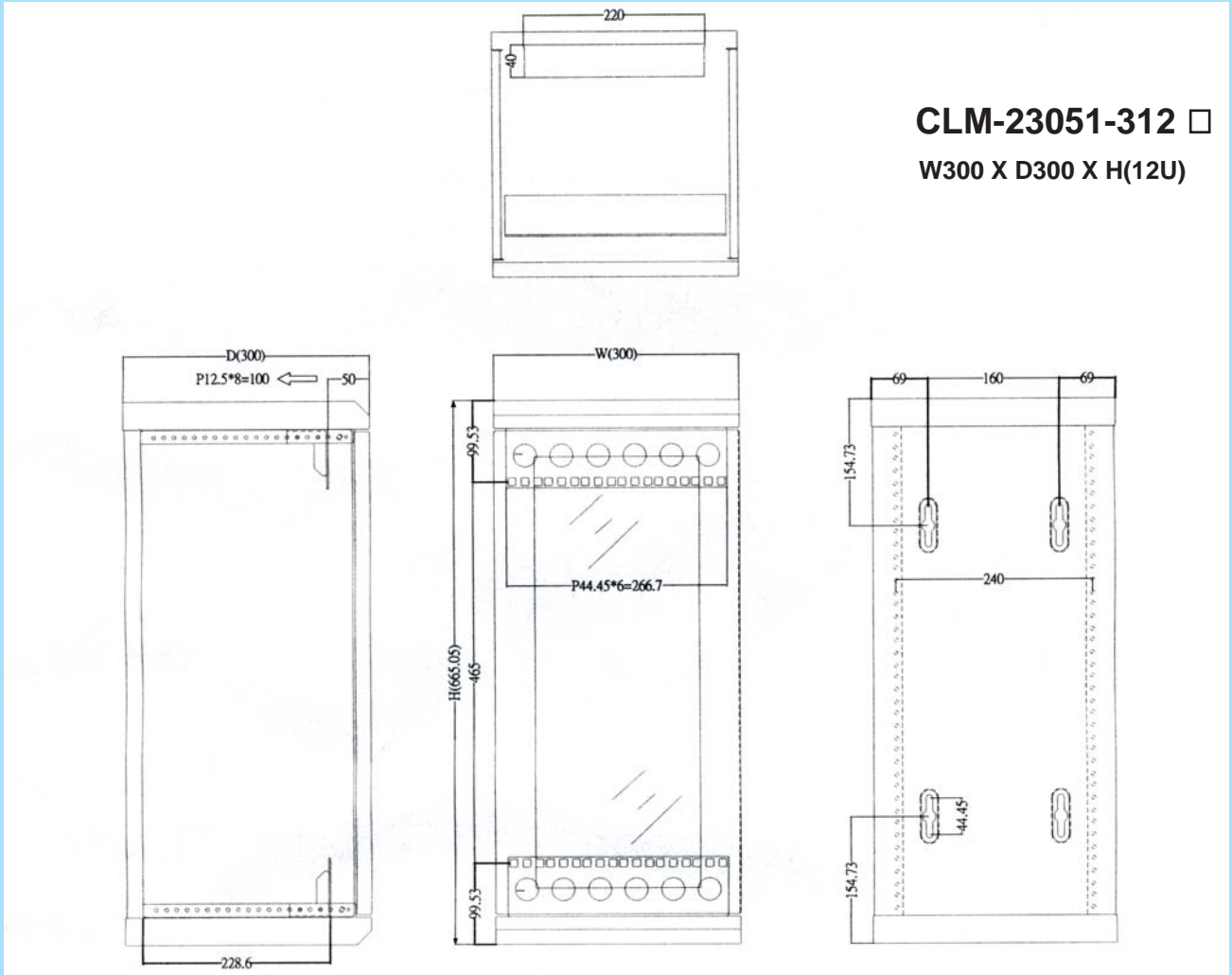

**CLM-23051-312 □**  
W300 X D300 X H(12U)

## Model No:CLM-23051-312 ■ Accessories For 19" cabling management

<b>Total Unit (U) :</b>		12
<b>Total Height (H) :</b>		665.05
<b>Width (W) :</b>		300
<b>Depth (D) :</b>		300
<b>Clearance Size (U) 1U=44.45mm</b>		533.4
<b>Shipping Dimension(completed):</b>		3.64
<b>G.W.:</b>		
<b>Standard Accessories(Included):</b>		<b>Pack No.</b>
1. CLM-612443-00 Wall-mounted hinge bracket	See page No.I 20	2
2. CLM-662009-12 Self-tapping washer screw, M6 X 12mm	See page No.K34	10
3. CLM-882003-06 Cage nut M6	See page No.K39	10
4. CLM-882099-00 L-shaped Angles	See page No.I 20	2

<b>Option Accessories</b>		<b>Pack No.</b>
1. CLM-882100-00 Cable clamp rails, in 10" width	Part No.CLM-612452-10 See page No. I 22	1
2. CLM-882113-00 1U mounting panel, in 10" width	Part No.CLM-612456-10 See page No. I 21	1
3. CLM-662097-1/4 Bolt-hinger screw	See page No. K37	4
4. CLM-312008-06 Power Socket strips	Complete No.CLM-882061-606 See page No. K30	1
5. CLM-312009-05 Power Socket strips	Complete No.CLM-882141-605 See page No. K30	1
6. CLM-612199-xx Cable shunting ring, steel-made ( H80 X W40 X D23 )	See page No. K19-1	10
7.CLM-612030-19 Cable clamp rails	See page No. K20	1
8.CLM-612122-19 Cable slunting strip	See page No. K19	1
9.CLM-882066-19 Cable entry panel	See page No. K19	1

Color choose : Fill number 5, 1 in the

5 - RAL7035

1 - RAL9011

# CLM-23051 10" WALL-MOUNT Rack

For Telecom Distributor Solutions



## Technical Functions:

- The widest 6U capacity for mounting 19" components from front in vertical
- For fixing cables or 10" components from rear by cable clamp rail in horizontal

## Standard Construction (Included):

- Material : Sheet Steel by strengthened stamping skills
- Front Door : 1 pc CLM-612445 with 3.0mm thickness strengthened glass with security Key-Lock, with 1 earth strap.
- Rear door : 1 pc CLM-612442
- Side panels: 2 pcs CLM-612444
- Roof & Bottom Panel: 2 pcs CLM-612441 vented & with 1 cable entry.
- Mounting Angles : 2 pcs CLM-882099(2 pcs CLM-612451) with 12 pcs CLM-512023-28
- Fastener-Hinger: 2 pcs CLM-612443 punched 2 Holes.
- Finished : Powder coating in color RAL 7035 or RAL 9011
- Shipping Dimension: CLM-23051-312: 3.64 Cuft



## Pended No:

Taiwan 187825 , 0534571 , 081293 , 91213894  
China ZL01342906.X  
USA 6,467,640B1, D463,794S, 10/364,335  
Germany 20111765.7 , 40108331.4

19" / 10" WALLMOUNT RACK



# CLM-23052 -312 10" Wallmount Rack Series

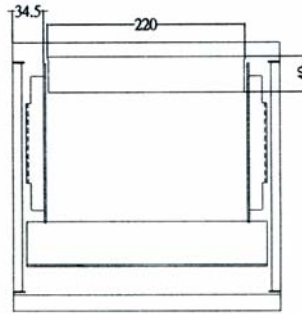

**CLM-23052-312** □  
W300 X D300 X H(12U)

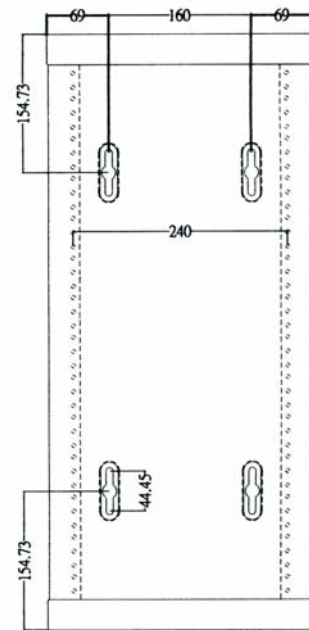
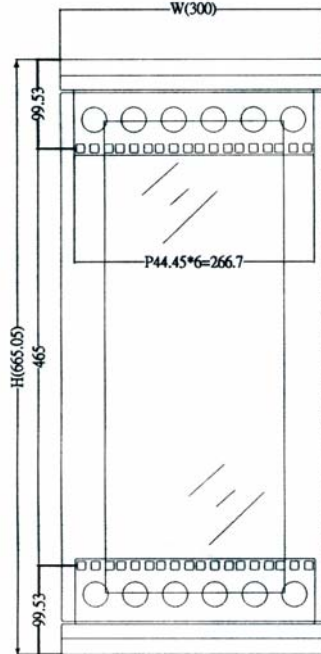
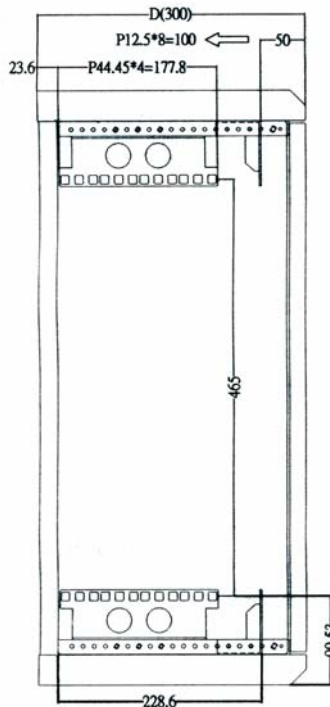

## Model No:CLM-23052-312 Accessories For 19" components

<b>Total Unit (U) :</b>	12
<b>Total Height (H) :</b>	665.05
<b>Width (W) :</b>	300
<b>Depth (D) :</b>	300
<b>Clearance Size (U) 1U=44.45mm</b>	533.4
<b>Shipping Dimension(completed):</b>	3.64
<b>G.W.:</b>	

Standard Accessories(Included):	Pack No.
1. CLM-612443-00 Wall-mounted hinge bracket See page NO. I 20	2
2. CLM-662009-12 Self-tapping washer screw, M6 X 12mm See page NO. K34	20
3. CLM-882003-06 Cage nut M6 See page NO. K39	20
4. CLM-882155-00 S-shaped Angles See page NO. I 20-2	4
5. CLM-882099-00 L-Shaped cabling Routing Angle See page NO. I 20	2

Option Accessories	Pack No.
1. CLM-882100-00 Cable clamp rails, for 10" width Part No.CLM-612452-00 See page No. I 22	1
2. CLM-882113-00 1U mounting panel, for 10" width Part No.CLM-612456-00 See page No. I 21	1
3. CLM-882112-00 1U Blanking panel, for 10" width Part No.CLM-612456-00 See page No. I 21	1
4. CLM-662097-1/4 Bolt-hinger screw See page No. K37	4
5. CLM-312008-06 Power Socket strips Complete No.CLM-882061-606 See page No. K30	1
6. CLM-312009-05 Power Socket strips Complete No.CLM-882141-605 See page No. K30	1
7.CLM-612199-xx Cable shunting ring, steel-made ( H80 X W40 X D23 ) See page No. K19-1	10

Color choose : Fill number 5, 1 in the

5 - RAL7035

1 - RAL9011

# CLM-23052 10" WALL-MOUNT Rack

## For Telecom Distributor Solutions



### Technical Functions:

- The widest 4U capacity for mounting vertical 19" components on Right or Left side & 6U capacity in vertical from front side.
- For fixing cables or 10" components in front or rear by cable clamp rail in Horizontal

### Standard Construction (Included):

- Material : Sheet Steel by strengthened stamping skills
- Front Door : 1 pc CLM-612445 with 3.0mm thickness strengthened glass with security Key-Lock, with 1 earth strap.
- Rear door : 1 pc CLM-612442
- Side panels: 2 pcs CLM-612444
- Roof & Bottom Panel: 2 pcs CLM-612441 vented & with 1 cable entry.
- Mounting Angles : 1 set CLM-882155-00 (4 pcs CLM-612450) with 8 pcs CLM-512023-28 plastic round ring & 1 set CLM-882099-00 (2 pcs CLM-612451) with 12 pcs CLM-512023-28 plastic round ring.
- Fastern-Hinger: 2 pcs CLM-612443 punched 2 Holes.
- Finished : Powder coating in color RAL 7035 or RAL 9011
- Shipping Dimension: CLM-23052-312: 3.64 Cuft

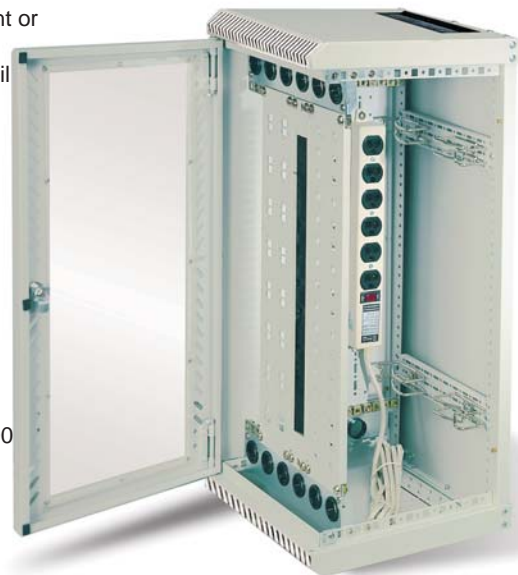

### Pended No:

Taiwan 187825 , 0534571 , 081293 , 91213894  
China ZL01342906.X  
USA 6,467,640B1, D463,794S, 10/364,335  
Germany 20111765.7 , 40108331.4

# CLM-23053 -312 ■ 10" Wallmount Rack Series

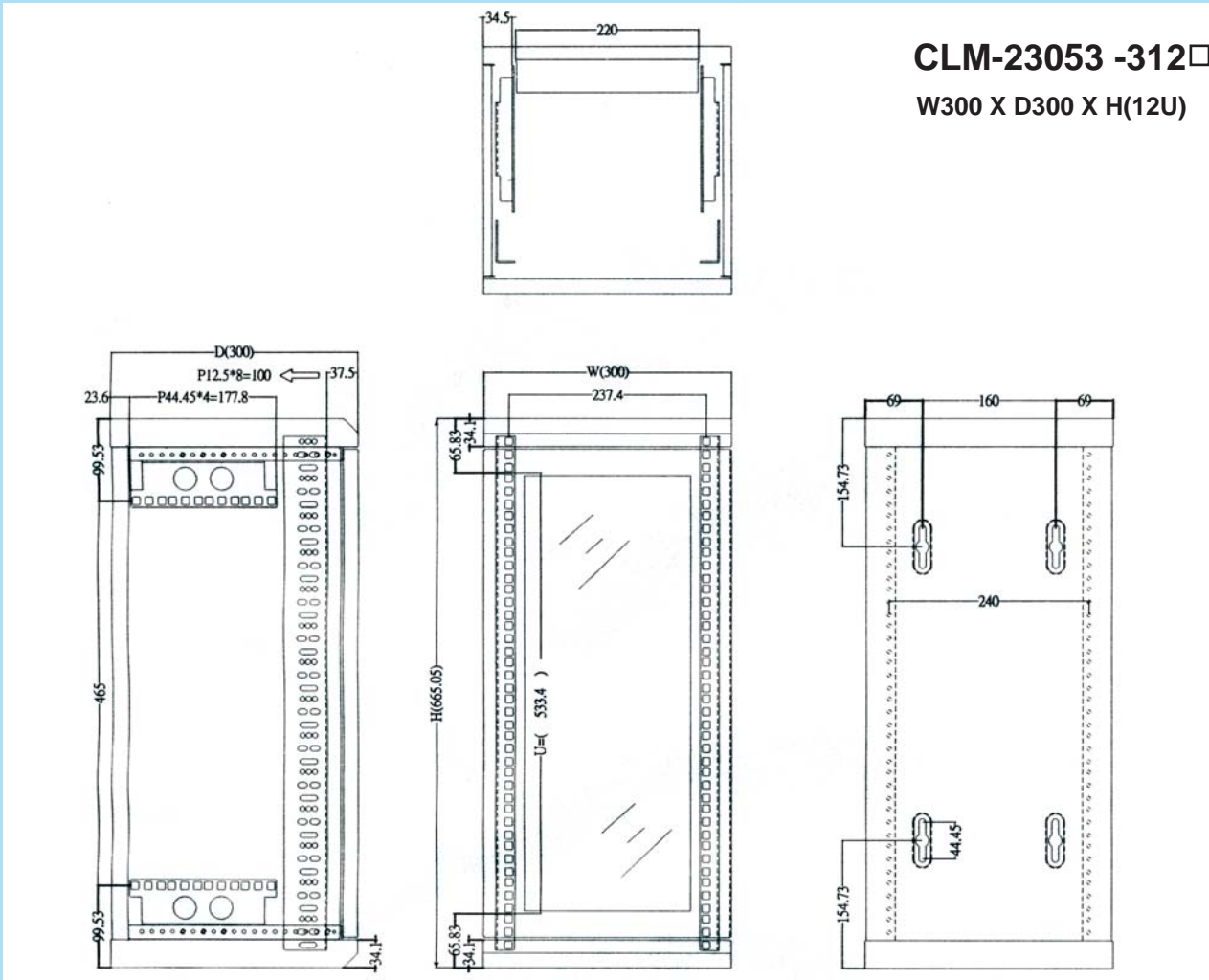

**CLM-23053 -312** □  
W300 X D300 X H(12U)

## Model No:CLM-23053 -312 ■ Accessories For 10"& 19" components

<b>Total Unit (U) :</b>	12
<b>Total Height (H) :</b>	665.05
<b>Width (W) :</b>	300
<b>Depth (D) :</b>	300
<b>Clearance Size (U) 1U=44.45mm</b>	533.4
<b>Shipping Dimension(completed):</b>	3.64
<b>G.W.:</b>	
<b>Standard Accessories(Included):</b>	<b>Pack No.</b>
1. CLM-612443-00 Wall-mounted hinge bracket	See page No. I 20 2
2. CLM-662009-12 Self-tapping washer screw, M6 X 12mm	See page No. K34 20
3. CLM-882003-06 Cage nut M6	See page No. K39 20
4. CLM-882155-00 S-shaped Angles	See page No. I20-2 4
5. CLM-612079-00 Mounting Angle	See page No. I19 2

<b>Option Accessories</b>	<b>Pack No.</b>
1. CLM-882100-00 Cable clamp rails, for 10" width	Part No.CLM-612452-00 See page No. I 22 1
2. CLM-882113-00 1U mounting panel, for 10" width	Part No.CLM-612456-00 See page No. I 21 1
3. CLM-882112-00 1U Blanking panel, for 10" width	Part No.CLM-612455-00 See page No. I 21 1
4. CLM-662097-1/4 Bolt-hinger screw	See page No. K37 4
5. CLM-882111-00 1U cable access panel, for 10" width	Part No.CLM-612454 See page No. I 21 1
6. CLM-882112-00 1U banking panel (sheet steel), for 10" width	Part No.CLM-612455 See page No. I 21 1
7. CLM-312008-06 Power Socket strips	Complete No.CLM-882061-606 See page No. K30 1
8. CLM-312009-05 Power Socket strips	Complete No.CLM-882141-605 See page No. K30 1
9. CLM-612199-xx Cable shunting ring, steel-made ( H80 X W40 X D23 )	See page No. K19-1 10

Color choose : Fill number 5, 1 in the

5 - RAL7035

1 - RAL9011



# CLM-23053 10" WALL-MOUNT Rack

## For Telecom Distributor Solutions



### Technical Functions:

- The widest 4U capacity for mounting 19" components from two sides in vertical
- For fixing cables & 10" components from front by cable clamp rail in Horizontal

### Standard Construction (Included):

- Material : Sheet Steel by strengthened stamping skills
- Front Door : 1 pc CLM-612445 with 3.0mm thickness strengthened glass with security Key-Lock, with 1 earth strap.
- Rear door : 1 pc CLM-612442
- Side panels: 2 pcs CLM-612444
- Roof & Bottom Panel: 2 pcs CLM-612441 vented & with 1 cable entry.
- Mounting Angles : 1 set CLM-882155-00 (4 pcs CLM-612450) with 8 pcs CLM-512023-28 plastic round ring & 2 pcs CLM-612079.
- Fastern-Hinger: 2 pcs CLM-612443 punched 2 Holes.
- Finished : Powder coating in color RAL 7035 or RAL 9011
- Shipping Dimension: CLM-23053-312: 3.64 Cuft



### Pended No:

Taiwan 187825 , 0534571 , 081293 , 91213894  
China ZL01342906.X  
USA 6,467,640B1, D463,794S, 10/364,335  
Germany 20111765.7 , 40108331.4

19" / 10" WALLMOUNT RACK

# CLM-2301x-x12U Ordering information for mounting 19" components (accessories) by CLM

CLM-2301  -

The "CLM" be your tailor-made & reliable Vendor to assemble your demand facility to save your free time & money.

After optional order 19" components(accessories)then fill out the Part No. & Description in the square Blank-space and point out the "U" postion let "CLM" to serve you to mounting on the cabinet.

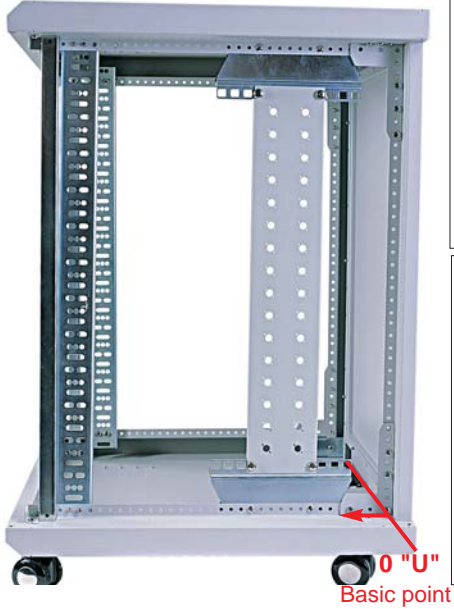

From Bottom on "Left" side

For "U" height mounting	1U	2U	3U	4U	5U	6U
CLM Part No.						
Description						

From Bottom on "Right" side

For "U" mounting on	6U	5U	4U	3U	2U	1U	For "U" mounting on
CLM Part No.							CLM Part No.
Description							Description

19" / 10" WALLMOUNT RACK

The starting point from Bottom in front 0 "U" to what "U" height for mounting 19" components(accessories)



For "U" height mounting	CLM Part No.	Description
21U		
20U		
19U		
18U		
17U		
16U		
15U		
14U		
13U		
12U		
11U		
10U		
9U		
8U		
7U		
6U		
5U		
4U		
3U		
2U		
1U		

# CLM-2305x-x12U Ordering information for mounting 19" components (accessories) by CLM

CLM-2305  -

After optional order 19" components(accessories)then fill out the Part No. & Description in the square Blank-space and point out the "U" position let "CLM" to serve you to mounting on the cabinet.

## CLM-2305x-x12U

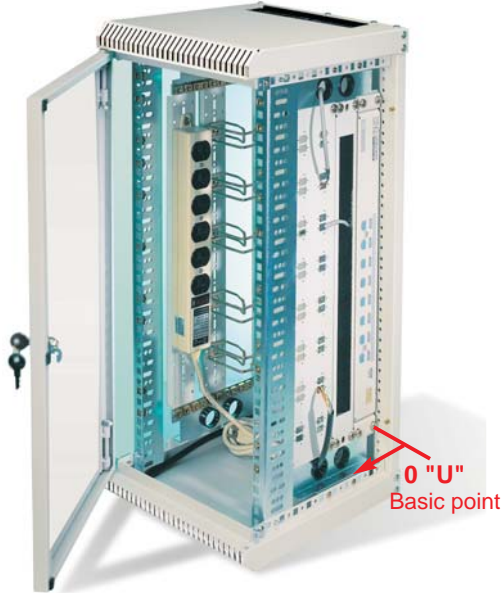

From Bottom on "Left" side

From Bottom on "Right" side

For "U" height mounting	1U	2U	3U	4U	4U	3U	2U	1U	For "U" height mounting
CLM Part No.									CLM Part No.
Description									Description

The starting point From front on right side 0 "U" to what "U" height for mounting 19" components(accessories)

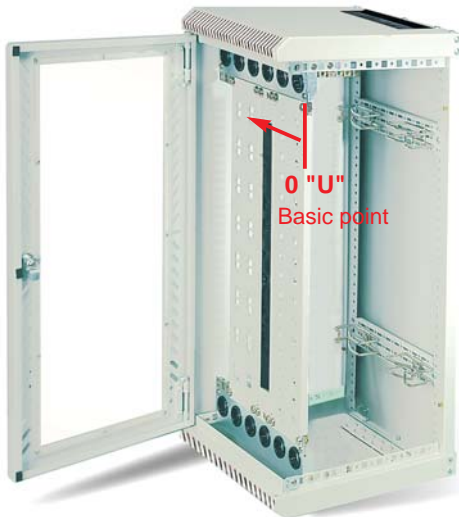

6U	5U	4U	3U	2U	1U	For "U" height mounting
						CLM Part No.
						Description

The starting point From front on right side 0 "U" to what "U" height for mounting 10" components(accessories)

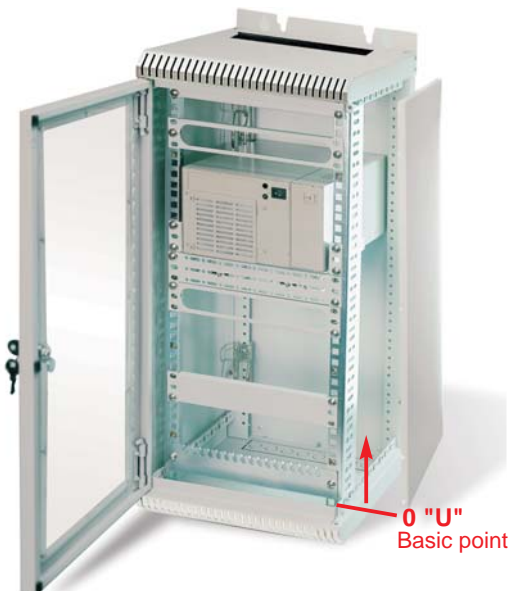

For "U" height mounting	CLM Part No.	Description
12U		
11U		
10U		
9U		
8U		
7U		
6U		
5U		
4U		
3U		
2U		
1U		